

**TREICHL-ATM Electronic** Auf der Bült 10 - 12 D 41189 Mönchengladbach  
Tel. 02166 958545 Fax 02166 958547 eMail: atm@treichl.de internet: www.atm-treichl.de

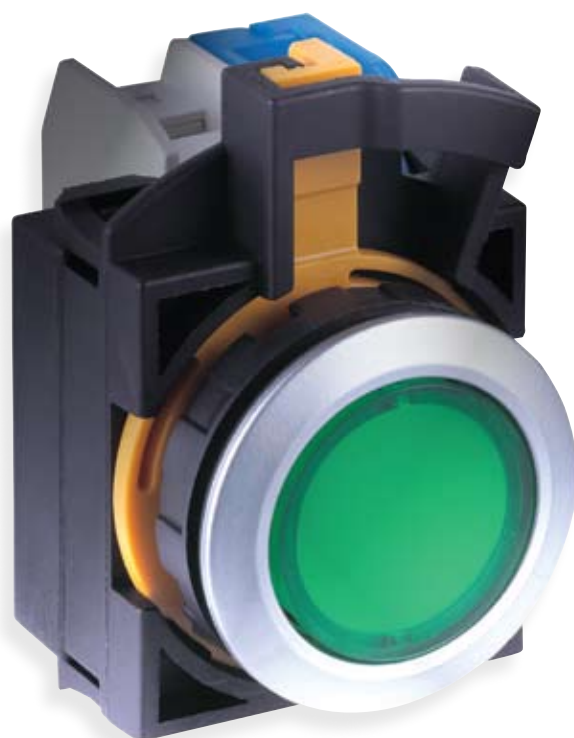

|||||

***ø22mm Flush Mount CW Series***  
*Switches & Pilot Devices*

# Safety, Style and Flexibility

## Safety



**Third-generation  
Safety Construction**

### Two-action removal of contact blocks

IDEC's original two-action push-turn locking lever provides a higher level of safety by preventing unexpected release of the locking lever. In addition, the position of the locking lever can be used to verify if the contact block was installed securely by checking from the back of the panel.

### Locking lever integrated with guard

Prevents locking lever from unexpected release or damage by trapped wires.



### IP20 Finger-safe Terminals

Finger-safe, IP20 terminals prevent electrical shock.



**Bezel**  
Black or metallic



Illuminated Pushbuttons - Page 6

- Round flush and extended
- Illumination colors: amber, blue, green, white, red, yellow



Non-illuminated Pushbuttons - Page 8

- Round flush and extended
- Button colors: black, blue, green, red, yellow, white



Pilot Lights - Page 9

- Round flush and extended
- Illumination colors: amber, blue, green, white, red, yellow

The IDEC commitment to assuring safety in all operating environments has resulted in stylish, compact and space-saving switches and pilot devices. The innovative two-step locking lever integrated with a guard provides a higher level of safety, and the low projection from the panel surface reduces the possibility of unexpected activation or operator damage. The CW series adds a sleek and stylish image to the panel with black or metallic bezels. The shortest depth behind the panel in its class contributes to reducing machine size.

## Design & Style

### Sleek and stylish switches with a 2.5mm-thick bezel

The CW series give a sleek, stylish image to your machine or control panel. Because of the slim profile, the surface is safer as there is less chance of unexpected operation or accident by hitting the switch. The design also means that the switch is cleaner as it has less dust build-up.

### Only 39.9mm depth behind the panel Space-saving design

Short depth behind the panel allows for smaller machines and panels. Up to 3 contact blocks (non-illuminated models) or 2 contact blocks (illuminated models) can be installed. Use with IDEC FB series or other control boxes.

- √ 300V AC, 10A contact rating
- √ No transformer needed—the same depth behind the panel—for any illumination voltage.

### Depth behind the panel comparison

The depth behind the panel of the CW series is shorter than conventional switches, reducing the amount of space needed in the control panel.

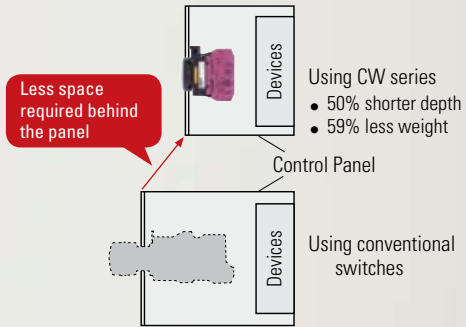
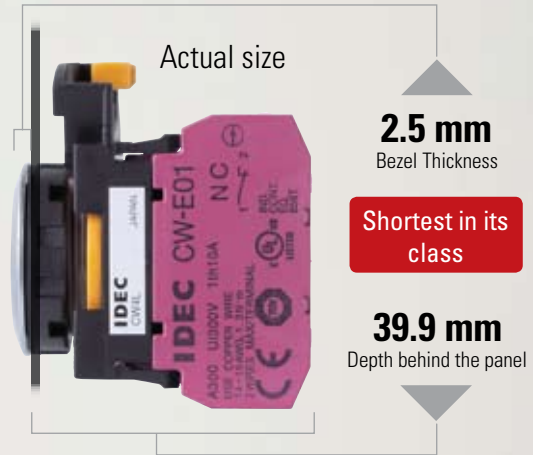

Selector Switches - Page 10

- Knob Operator 2- and 3-position



Selector Switches - Page 10

- Lever Operator 2- and 3-position
- Lever operator with an easy grip



Key Selector Switches - Page 13

- 7 different wave-keys available
- Hard to duplicate, wave-key ensures a high level of safety



# ø22mm Flush Mount CW Switches & Pilot Devices

Flush bezel projects only 2.5mm from front of panel and only 39.9mm behind the panel!

- ø22.3mm mounting hole compliant with IEC 60947-5-1
- 3.5-mm operator travel for pushbuttons ensures comfortable and reliable operation
- Black and metallic bezels available
- Illuminated pushbuttons, pushbuttons, pilot lights, selector switches and key selector switches are available
- Direct opening NC contact
- Seven different keys can be chosen for key selector switches
- 10A contact rating; up to three contact blocks for non-illuminated and two contact blocks for illuminated models can be connected
- Contact blocks can be removed by the two-action locking lever integrated with a guard, ensuring safety
- IP20 finger-safe screw terminals
- IP65 degree of protection (IEC 60529) from panel front



Applicable Standards	Mark	File No. or Organization
UL508 CSA C22.2 No.14		UL/c-UL File No. E68961
EN60947-5-1		TÜV SÜD
		EC Low Voltage Directive

## Contact Ratings

Rated Insulation Voltage (Ui)				300V		
Rated Thermal Current (Ith)				10A		
Rated Operating Voltage (Ue)				24V	120V	240V
Rated Operating Current (Ie)	Electrical Life 50,000 operations	AC 50/60 Hz	Resistive Load (AC-12)	10A	10A	6A
			Inductive Load (AC-15)	10A	6A	3A
		DC	Resistive Load (DC-12)	8A	2.2A	1.1A
			Inductive Load (DC-13)	4A	1.1A	0.55A
	Electrical Life 100,000 operations	AC 50/60 Hz	Resistive Load (AC-12)	5A	5A	3A
			Inductive Load (AC-15)	5A	3A	1.5A
		DC	Resistive Load (DC-12)	4A	1.1A	0.55A
			Inductive Load (DC-13)	2A	0.55A	0.27A
Contact Material				Silver		

1. Minimum applicable load (reference value): 3V AC/DC, 5 mA (Applicable range is subject to the operating conditions and load.)
2. The operational current represents the classification by making and breaking currents (IEC 60947-5-1).
3. UL, c-UL rating: A300

## Weights

Illuminated Pushbutton	46g (CW1L-M1E02QH, 2 contact blocks)
Pushbutton	45g (CW1B-M1E03, 3 contact blocks)
Pilot Light	27g (CW1P-1EQH)
Selector Switch	48g (CW1S-2E03, 3 contact blocks)
Key Selector Switch	61g (CW1K-2E03, 3 contact blocks)

## Specifications

Operating Temperature	Non-illuminated: -25 to +60°C (no freezing) LED illuminated: -25 to +55°C (no freezing)
Operating Humidity	45 to 85% RH (no condensation)
Storage Temperature	-40 to +80°C
Contact Resistance	50 mΩ maximum (initial value)
Insulation Resistance	100 MΩ minimum (500V DC megger)
Overtoltage Category	II (IEC 60664-1)
Impulse Withstand Voltage	2.5 kV (IEC60664-1/60947-5-1)
Pollution Degree	3 (IEC60947-5-1)
Vibration Resistance	Operating extremes: 5 to 55Hz, amplitude 0.5 mm
Shock Resistance	Operating extremes: 100 m/s <sup>2</sup> Damage limits: 1000 m/s <sup>2</sup>
Mechanical Life (minimum operations)	Pushbutton, illuminated pushbutton: 2,000,000 Selector switch: 250,000 Key selector switch: 250,000
Electrical Life (minimum operations)	50,000 (see Contact Ratings) 100,000 (see Contact Ratings) (switching frequency 1800 operations/h)
Degree of Protection (IEC60529)	Panel front: IP65 Terminals: IP20
Short-circuit Protection	250V/10A fuse, (Type aM IEC60269-1, IEC602069-2)
Electrical Shock Protection	Class II (IEC61140)
Terminal Style	Screw terminal (M3.5 slotted Phillips screw)
Bezel Material	Polyamide
Applicable Wire Size	Up to 2 wires of 2 mm <sup>2</sup> (solid wire ø1.6) maximum (AWG14 to 16) (Ring terminal cannot be used)
Recommended Tightening Torque	Terminal: 1.0 to 1.3 N-m Locking ring: 1.2 N-m

## Direct Opening of Key Selector Switch

	2-position (3NC)	3-position (2NC)
Operator Angle for Direct Opening Action	90°	45°
Minimum Operator Torque for Direct Opening Action	0.2 N-m	0.3 N-m
Maximum Operator Angle	90°	45°

### LED Module

Rated Insulation Voltage (Ui)	250V				
Rated Operating Voltage (Ue)	6V AC/DC	12V AC/DC	24V AC/DC	100/120V AC	230/240V AC
Operating Voltage Range	6V AC/DC±10%	12V AC/DC±10%	24V AC/DC±10%	100/120V AC±10%	230/240V AC 10%
Illumination Color Code ⊙	A (amber), G (green), PW (white), R (red), S (blue)				
LED Module Part Number	CW-EAQ2⊙	CW-EAQ3⊙	CW-EAQ4⊙	CW-EAQH⊙	CW-EAQM4⊙
Current Draw	15 mA	15 mA	16.5 mA	18 mA	18 mA
Life (reference value)	Approx. 30,000 hours				
Internal Circuit					

- Specify an illumination color code in place of ⊙ in the part number.
- Use the white (PW) LED module for yellow illumination.

### Mounting Hole Layout

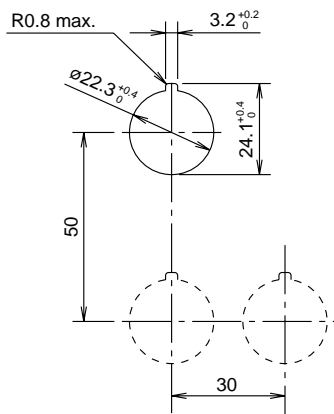

#### IEC 60947-5-1 compliant



Note: Determine mounting centers to ensure proper spacing.



### Illuminated Pushbuttons (Assembled)

Shape	Operation	Operating Voltage	Contact Configuration	Black Bezel	Metallic Bezel	Illumination Color Code ☺
Round Flush CW□L-M1   (black bezel)   (metallic bezel)	Momentary	6V AC/DC	1NO	CW1L-M1E10Q2☺	CW4L-M1E10Q2☺	A: amber G: green PW: white R: red S: blue Y: yellow
			1NC	CW1L-M1E01Q2☺	CW4L-M1E01Q2☺	
			1NO-1NC	CW1L-M1E11Q2☺	CW4L-M1E11Q2☺	
			2NO	CW1L-M1E20Q2☺	CW4L-M1E20Q2☺	
			2NC	CW1L-M1E02Q2☺	CW4L-M1E02Q2☺	
			2NO	CW1L-M1E10Q3☺	CW4L-M1E10Q3☺	
		12V AC/DC	1NC	CW1L-M1E01Q3☺	CW4L-M1E01Q3☺	
			1NO-1NC	CW1L-M1E11Q3☺	CW4L-M1E11Q3☺	
			2NO	CW1L-M1E20Q3☺	CW4L-M1E20Q3☺	
			2NC	CW1L-M1E02Q3☺	CW4L-M1E02Q3☺	
			1NO	CW1L-M1E10Q4☺	CW4L-M1E10Q4☺	
			1NC	CW1L-M1E01Q4☺	CW4L-M1E01Q4☺	
		24V AC/DC	1NO-1NC	CW1L-M1E11Q4☺	CW4L-M1E11Q4☺	
			2NO	CW1L-M1E20Q4☺	CW4L-M1E20Q4☺	
			2NC	CW1L-M1E02Q4☺	CW4L-M1E02Q4☺	
			1NO	CW1L-M1E10QH☺	CW4L-M1E10QH☺	
			1NC	CW1L-M1E01QH☺	CW4L-M1E01QH☺	
			1NO-1NC	CW1L-M1E11QH☺	CW4L-M1E11QH☺	
		100/120V AC	2NO	CW1L-M1E20QH☺	CW4L-M1E20QH☺	
			2NC	CW1L-M1E02QH☺	CW4L-M1E02QH☺	
			1NO	CW1L-M1E10QM4☺	CW4L-M1E10QM4☺	
			1NC	CW1L-M1E01QM4☺	CW4L-M1E01QM4☺	
			1NO-1NC	CW1L-M1E11QM4☺	CW4L-M1E11QM4☺	
			2NO	CW1L-M1E20QM4☺	CW4L-M1E20QM4☺	
230/240V AC	2NC	CW1L-M1E02QM4☺	CW4L-M1E02QM4☺			
	1NO	CW1L-M2E10Q2☺	CW4L-M2E10Q2☺			
	1NC	CW1L-M2E01Q2☺	CW4L-M2E01Q2☺			
	1NO-1NC	CW1L-M2E11Q2☺	CW4L-M2E11Q2☺			
	2NO	CW1L-M2E20Q2☺	CW4L-M2E20Q2☺			
	2NC	CW1L-M2E02Q2☺	CW4L-M2E02Q2☺			
12V AC/DC	1NO	CW1L-M2E10Q3☺	CW4L-M2E10Q3☺			
	1NC	CW1L-M2E01Q3☺	CW4L-M2E01Q3☺			
	1NO-1NC	CW1L-M2E11Q3☺	CW4L-M2E11Q3☺			
	2NO	CW1L-M2E20Q3☺	CW4L-M2E20Q3☺			
	2NC	CW1L-M2E02Q3☺	CW4L-M2E02Q3☺			
	1NO	CW1L-M2E10Q4☺	CW4L-M2E10Q4☺			
24V AC/DC	1NC	CW1L-M2E01Q4☺	CW4L-M2E01Q4☺			
	1NO-1NC	CW1L-M2E11Q4☺	CW4L-M2E11Q4☺			
	2NO	CW1L-M2E20Q4☺	CW4L-M2E20Q4☺			
	2NC	CW1L-M2E02Q4☺	CW4L-M2E02Q4☺			
	1NO	CW1L-M2E10QH☺	CW4L-M2E10QH☺			
	1NC	CW1L-M2E01QH☺	CW4L-M2E01QH☺			
100/120V AC	1NO-1NC	CW1L-M2E11QH☺	CW4L-M2E11QH☺			
	2NO	CW1L-M2E20QH☺	CW4L-M2E20QH☺			
	2NC	CW1L-M2E02QH☺	CW4L-M2E02QH☺			
	1NO	CW1L-M2E10QM4☺	CW4L-M2E10QM4☺			
	1NC	CW1L-M2E01QM4☺	CW4L-M2E01QM4☺			
	1NO-1NC	CW1L-M2E11QM4☺	CW4L-M2E11QM4☺			
230/240V AC	2NO	CW1L-M2E20QM4☺	CW4L-M2E20QM4☺			
	2NC	CW1L-M2E02QM4☺	CW4L-M2E02QM4☺			

- Specify an illumination color code in place of ☺ in the Part Number.
- See page 16 for dimensions.
- See page next page for replacement LED modules.
- A dummy block is installed when one contact block is used.
- Momentary: The contact operates when button is pressed and returns when released.

## Illuminated Pushbuttons (Sub-assembled)



### Contact Block

Style	Contacts	1NO	1NC
	Finger-safe Screw terminal	CW-E10	CW-E01
	Dummy block	CW-DB	

### Operator

Style		Black Bezel	Metallic Bezel
	Round flush	CW1L-M10	CW4L-M10
	Round extended	CW1L-M20	CW4L-M20

### LED Module

Style	Part Number
	CW-EAQ ②①

1. In place of ①, specify the Lens/LED Color Code from table.
2. In place of ②, specify the Voltage Code from table.

### Lens

Style		Part number
	Round flush	CW9Z-L11①
	Round extended	CW9Z-L12①

1. In place of ①, specify the Lens/LED Color Code from table.

### Contact Block Mounting Adaptor

Style	Part Number
	CW-CN



#### ① Lens/LED Color Code

Color	Code
Amber	A
Green	G
Red	R
Blue	S
White	PW
Yellow	Y

#### ② Voltage Code

Voltage	Code
6V AC/DC	2
12V AC/DC	3
24V AC/DC	4
100/120V AC	H
230/240V AC	M4

## Non-illuminated Pushbuttons (Assembled)

Shape	Operation	Contact Configuration	Black Bezel	Metallic Bezel	Button Color Code ①
Round Flush CW□B-M1  (black bezel)	Momentary	1NO	CW1B-M1E10①	CW4B-M1E10①	B: black G: green R: red S: blue W: white Y: yellow
		1NC	CW1B-M1E01①	CW4B-M1E01①	
		1NO-1NC	CW1B-M1E11①	CW4B-M1E11①	
		2NO	CW1B-M1E20①	CW4B-M1E20①	
		2NC	CW1B-M1E02①	CW4B-M1E02①	
		2NO-1NC	CW1B-M1E21①	CW4B-M1E21①	
		1NO-2NC	CW1B-M1E12①	CW4B-M1E12①	
		3NO	CW1B-M1E30①	CW4B-M1E30①	
3NC	CW1B-M1E03①	CW4B-M1E03①			
Round Extended CW□B-M2  (metallic bezel)	Momentary	1NO	CW1B-M2E10①	CW4B-M2E10①	
		1NC	CW1B-M2E01①	CW4B-M2E01①	
		1NO-1NC	CW1B-M2E11①	CW4B-M2E11①	
		2NO	CW1B-M2E20①	CW4B-M2E20①	
		2NC	CW1B-M2E02①	CW4B-M2E02①	
		2NO-1NC	CW1B-M2E21①	CW4B-M2E21①	
		1NO-2NC	CW1B-M2E12①	CW4B-M2E12①	
		3NO	CW1B-M2E30①	CW4B-M2E30①	
3NC	CW1B-M2E03①	CW4B-M2E03①			

1. Specify a button color code in place of ① in the part number.
2. See page 16 for dimensions.
3. Two or one dummy block is installed when one or two contact blocks are used, respectively.
4. Momentary: the contact operates when button is pressed and returns when released.

## Non-illuminated Pushbuttons (Sub-assembled)

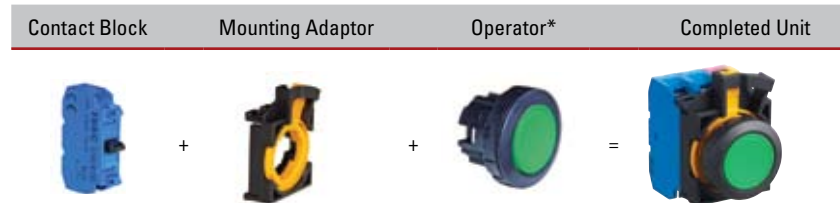

### Contact Block

Style	Contacts	1NO	1NC
 	Finger-safe Screw terminal	CW-E10	CW-E01
	Dummy block	CW-DB	



### Contact Block Mounting Adaptor

Style	Part Number
	CW-CN

### ① Button Color Code

Color	Code
Black	B
Green	G
Red	R
Blue	S
White	W
Yellow	Y



### Operator\*

Style	Black Bezel	Metallic Bezel
 Round flush	CW1B-M1①	CW4B-M1①
 Round extended	CW1B-M2①	CW4B-M2①

1. Specify a button color code in place of ①.
2. \*Operator button is not removable from operator.



## Pilot Lights (Assembled)

Shape	Operating Voltage	Black Bezel	Metallic Bezel	Illumination Color Code ②
Round Flush CW□P-1  (black bezel)	6V AC/DC	CW1P-1EQ2②	CW4P-1EQ2②	A: amber G: green R: red S: blue PW: white Y: yellow
	12V AC/DC	CW1P-1EQ3②	CW4P-1EQ3②	
	24V AC/DC	CW1P-1EQ4②	CW4P-1EQ4②	
	100/120V AC	CW1P-1EQH②	CW4P-1EQH②	
	230/240V AC	CW1P-1EQM4②	CW4P-1EQM4②	
Round Dome Lens CW□P-2  (metallic bezel)	6V AC/DC	CW1P-2EQ2②	CW4P-2EQ2②	
	12V AC/DC	CW1P-2EQ3②	CW4P-2EQ3②	
	24V AC/DC	CW1P-2EQ4②	CW4P-2EQ4②	
	100/120V AC	CW1P-2EQH②	CW4P-2EQH②	
	230/240V AC	CW1P-2EQM4②	CW4P-2EQM4②	

1. Specify an illumination color code in place of ② in the Part Number
2. See page 16 for dimensions.
3. See page 18 for replacement LED modules.
4. Two dummy blocks are installed.

## Pilot Lights (Sub-assembled)





### Contact Block

Style	Part Number
	Dummy block CW-DB

### Contact Block Mounting Adaptor

Style	Part Number
	CW-CN

### Lens

Style	Part number
	Round flush CW9Z-L11①
	Round dome CW9Z-L15①

1. In place of ①, specify the Lens/LED Color Code from table.

### LED Module

Style	Part Number
	CW-EAQ ②①

1. In place of ①, specify the Lens/LED Color Code from table.
2. In place of ②, specify the Voltage Code from table.

### Operator

Style	Black Bezel	Metallic Bezel
	CW1P-00	CW4P-00
		



### ① Lens/LED Color Code

Color	Code
Amber	A
Green	G
Red	R
Blue	S
White	PW
Yellow	Y

### ② Voltage Code

Voltage	Code
6V AC/DC	2
12V AC/DC	3
24V AC/DC	4
100/120V AC	H
230/240V AC	M4

### Selector Switches (Assembled)

Shape	CW□S (Knob Operator)		 (black bezel)  (metallic bezel)				
	No. of Positions	Contact Configuration	Contact Block		Operator Position		 Latched
90° 2-position	1NO (10)	1	NO		●	CW□S-2E10	CW□S-21E10
		2	—	Dummy			
		3	—	Dummy			
	1NC (01)	1	—	Dummy		CW□S-2E01	CW□S-21E01
		2	—	Dummy			
		3	NC	●			
	1NO-1NC (11)	1	NO		●	CW□S-2E11	CW□S-21E11
		2	—	Dummy			
		3	NC	●			
	2NO (20)	1	NO		●	CW□S-2E20	CW□S-21E20
		2	—	Dummy			
		3	NO		●		
	2NC (02)	1	NC	●		CW□S-2E02	CW□S-21E02
		2	—	Dummy			
		3	NC	●			
	2NO-1NC (21)	1	NO		●	CW□S-2E21	CW□S-21E21
		2	NO		●		
		3	NC	●			
1NO-2NC (12)	1	NO		●	CW□S-2E12	CW□S-21E12	
	2	NC	●				
	3	NC	●				
3NO (30)	1	NO		●	CW□S-2E30	CW□S-21E30	
	2	NO		●			
	3	NO		●			
3NC (03)	1	NC	●		CW□S-2E03	CW□S-21E03	
	2	NC	●				
	3	NC	●				

1. Specify a bezel color code in place of □ in the part number: 1 (black bezel), 4 (metallic bezel).
2. Lever operator is also available. For dimensions, see page 17.
3. To order a lever operator selector switch, insert L before E in the knob operator part number.  
Example: Knob Operator part number CW1S-2E10 becomes CW1S-2LE10 for Lever Operator.

#### Lever Operator



CW1S-□L  
(black bezel)





CW4S-□L  
(metallic bezel)

#### Contact Block Mounting Position

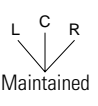
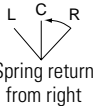

		Left	Center	Right	
		L	C	R	← Operator Position
1	NO	●			
2	NC		●		
3	NC	●			

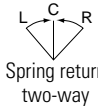
No. of Positions	Contact Configuration	Contact Block		Operator Position							
		Mounting Position	Type	L	C	R					
45° 3-position	1NO-1NC (11)	1	NO	●			CW□S-3E11	CW□S-31E11	CW□S-32E11	CW□S-33E11	
		2	—		Dummy						
		3	NC	■							
	1NO-1NC (11N1)	1	NC		■			CW□S-3E11N1	CW□S-31E11N1	CW□S-32E11N1	CW□S-33E11N1
		2	—		Dummy						
		3	NO			●					
	1NO-1NC (11N2)	1	NO	●			CW□S-3E11N2	CW□S-31E11N2	CW□S-32E11N2	CW□S-33E11N2	
		2	NC		●						
		3	—		Dummy						
	1NO-1NC (11N3)	1	—		Dummy			CW□S-3E11N3	CW□S-31E11N3	CW□S-32E11N3	CW□S-33E11N3
		2	NC		●						
		3	NO			●					
	1NO-1NC (11N4)	1	—		Dummy			CW□S-3E11N4	CW□S-31E11N4	CW□S-32E11N4	CW□S-33E11N4
		2	NO	●		●					
		3	NC	■							
	2NO (20)	1	NO	●			CW□S-3E20	CW□S-31E20	CW□S-32E20	CW□S-33E20	
		2	—		Dummy						
		3	NO			●					
	2NO (20N1)	1	—		Dummy			CW□S-3E20N1	CW□S-31E20N1	CW□S-32E20N1	CW□S-33E20N1
		2	NO	●		●					
		3	NO			●					
	2NC (02)	1	NC		■			CW□S-3E02	CW□S-31E02	CW□S-32E02	CW□S-33E02
		2	—		Dummy						
		3	NC	■							
2NC (02N1)	1	—		Dummy			CW□S-3E02N1	CW□S-31E02N1	CW□S-32E02N1	CW□S-33E02N1	
	2	NC		●							
	3	NC	■								
2NO-1NC (21)	1	NO	●			CW□S-3E21	CW□S-31E21	CW□S-32E21	CW□S-33E21		
	2	NO	●		●						
	3	NC	■								
2NO-1NC (21N1)	1	NO	●			CW□S-3E21N1	CW□S-31E21N1	CW□S-32E21N1	CW□S-33E21N1		
	2	NC		●							
	3	NO			●						
1NO-2NC (12)	1	NO	●			CW□S-3E12	CW□S-31E12	CW□S-32E12	CW□S-33E12		
	2	NC		●							
	3	NC	■								
1NO-2NC (12N1)	1	NC		■			CW□S-3E12N1	CW□S-31E12N1	CW□S-32E12N1	CW□S-33E12N1	
	2	NO	●		●						
	3	NC	■								
3NO (30)	1	NO	●			CW□S-3E30	CW□S-31E30	CW□S-32E30	CW□S-33E30		
	2	NO	●		●						
	3	NO			●						
3NC (03)	1	NC		■			CW□S-3E03	CW□S-31E03	CW□S-32E03	CW□S-33E03	
	2	NC		●							
	3	NC	■								

1. Specify a bezel color code in place of □ in the Part Number, 1 (black bezel), 4 (metallic bezel)
  2. For the contact block mounting position, see page 10.
  3. Lever operator is also available. For dimensions, see page 17.
  4. To order a lever operator selector switch, insert L before E in the knob operator part number.
- Example: Knob Operator part number CW1S-3E11 becomes CW1S-3LE11 for Lever Operator.

## Selector Switches (Sub-assembled)





### Contact Block

Style	Contacts	1NO	1NC
 	Finger-safe Screw terminal	CW-E10	CW-E01
	Dummy block	CW-DB	

### Contact Block Mounting Adaptor

Style	Part Number
	CW-CN

### Operator

Style	Position	Handle	Description	Black Bezel	Metallic Bezel
  (lever operator shown)	2 position	Knob	Maintained	CW1S-2	CW4S-2
			Spring return from right	CW1S-21	CW4S-21
		Lever	Maintained	CW1L-2	CW4L-2
			Spring return from right	CW1L-21	CW4L-21
	3 position	Knob	Maintained	CW1S-3	CW4S-3
			Spring return from right	CW1S-31	CW4S-31
			Spring return from left	CW1S-32	CW4S-32
			Spring return two-way	CW1S-33	CW4S-33
		Lever	Maintained	CW1L-3	CW4L-3
			Spring return from right	CW1L-31	CW4L-31
			Spring return from left	CW1L-32	CW4L-32
			Spring return two-way	CW1L-33	CW4L-33

Lever or knob is supplied with operator

## Key Selector Switches (Assembled)

No. of Positions	Contact Configuration	Contact Block		Operator Position		 Maintained	 Spring return from right
		Mounting Position	Type	L	R		
90° 2-position	1NO (10)	1	NO		●	CW□K-2AE10	CW□K-21BE10
		2	—	Dummy			
		3	—	Dummy			
	1NC (01)	1	—	Dummy		CW□K-2AE01	CW□K-21BE01
		2	—	Dummy			
		3	NC	●			
	1NO-1NC (11)	1	NO		●	CW□K-2AE11	CW□K-21BE11
		2	—	Dummy			
		3	NC	●			
	2NO (20)	1	NO		●	CW□K-2AE20	CW□K-21BE20
		2	—	Dummy			
		3	NO		●		
	2NC (02)	1	NC	●		CW□K-2AE02	CW□K-21BE02
		2	—	Dummy			
		3	NC	●			
	2NO-1NC (21)	1	NO		●	CW□K-2AE21	CW□K-21BE21
		2	NO		●		
		3	NC	●			
	1NO-2NC (12)	1	NO		●	CW□K-2AE12	CW□K-21BE12
		2	NC	●			
		3	NC	●			
	3NO (30)	1	NO		●	CW□K-2AE30	CW□K-21BE30
		2	NO		●		
		3	NO		●		
3NC (03)	1	NC	●		CW□K-2AE03	CW□K-21BE03	
	2	NC	●				
	3	NC	●				

- Specify a bezel color code in place of □ in the Part Number: 1 (black bezel), 4 (metallic bezel).
- On the spring-returned models, the key can be released only from the maintained position. On the maintained models, the key can be released from any position. Key retained positions are also available. See below.
- Two keys are supplied.
- Key cylinder material: Metal
- Besides the standard key (key number 0H), six other keys are also available. See below.
- For the contact block mounting position, see page 14.
- For dimensions, see page 17.
- When ordering an optional key or optional key retained positions, specify designation codes as shown below:

Example: CW1K-2AE10-1H

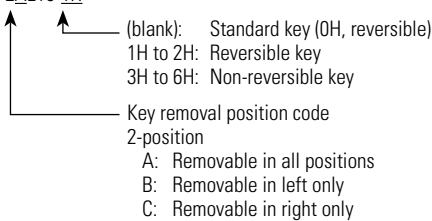

Note:  
 Key number is indicated on the key cylinder.  
 Standard keys do not have a key number indication.

3-position

- A: Removable in all positions
- B: Removable in left and center
- C: Removable in right and center
- D: Removable in center only
- E: Removable in right and left
- G: Removable in left only
- H: Removable in right only

Note: Key is retained in all spring-returned positions.

No. of Positions	Contact Configuration	Contact Block		Operator Position			 Maintained	 Spring return from right	 Spring return from left	 Spring return two-way
		Mounting Position	Type	L	C	R				
45° 3-position	1NO-1NC (11)	1	NO	●			CW□K-3AE11	CW□K-31BE11	CW□K-32CE11	CW□K-33DE11
		2	—	Dummy						
		3	NC	■						
	1NO-1NC (11N1)	1	NC		■		CW□K-3AE11N1	CW□K-31BE11N1	CW□K-32CE11N1	CW□K-33DE11N1
		2	—	Dummy						
		3	NO			●				
	1NO-1NC (11N2)	1	NO	●			CW□K-3AE11N2	CW□K-31BE11N2	CW□K-32CE11N2	CW□K-33DE11N2
		2	NC		●					
		3	—	Dummy						
	1NO-1NC (11N3)	1	—	Dummy			CW□K-3AE11N3	CW□K-31BE11N3	CW□K-32CE11N3	CW□K-33DE11N3
		2	NC		●					
		3	NO			●				
	1NO-1NC (11N4)	1	—	Dummy			CW□K-3AE11N4	CW□K-31BE11N4	CW□K-32CE11N4	CW□K-33DE11N4
		2	NO	●		●				
		3	NC	■						
	2NO (20)	1	NO	●			CW□K-3AE20	CW□K-31BE20	CW□K-32CE20	CW□K-33DE20
		2	—	Dummy						
		3	NO			●				
	2NO (20N1)	1	—	Dummy			CW□K-3AE20N1	CW□K-31BE20N1	CW□K-32CE20N1	CW□K-33DE20N1
		2	NO	●		●				
		3	NO			●				
	2NC (02)	1	NC		■		CW□K-3AE02	CW□K-31BE02	CW□K-32CE02	CW□K-33DE02
		2	—	Dummy						
		3	NC	■						
	2NC (02N1)	1	—	Dummy			CW□K-3AE02N1	CW□K-31BE02N1	CW□K-32CE02N1	CW□K-33DE02N1
		2	NC		●					
		3	NC	■						
	2NO-1NC (21)	1	NO	●			CW□K-3AE21	CW□K-31BE21	CW□K-32CE21	CW□K-33DE21
		2	NO	●		●				
		3	NC	■						
2NO-1NC (21N1)	1	NO	●			CW□K-3AE21N1	CW□K-31BE21N1	CW□K-32CE21N1	CW□K-33DE21N1	
	2	NC		●						
	3	NO			●					
1NO-2NC (12)	1	NO	●			CW□K-3AE12	CW□K-31BE12	CW□K-32CE12	CW□K-33DE12	
	2	NC		●						
	3	NC	■							
1NO-2NC (12N1)	1	NC		■		CW□K-3AE12N1	CW□K-31BE12N1	CW□K-32CE12N1	CW□K-33DE12N1	
	2	NO	●		●					
	3	NC	■							
3NO (30)	1	NO	●			CW□K-3AE30	CW□K-31BE30	CW□K-32CE30	CW□K-33DE30	
	2	NO	●		●					
	3	NO			●					
3NC (03)	1	NC		■		CW□K-3AE03	CW□K-31BE03	CW□K-32CE03	CW□K-33DE03	
	2	NC		●						
	3	NC	■							

1. Specify a bezel color code in place of □ in the Type No.: 1 (black bezel), 4 (metallic bezel)
2. On the spring-returned types, the key can be released only from the maintained position. On the maintained types, the key can be released from every position. Key retained positions are also available. See page 13.
3. Two keys are supplied.
4. Key cylinder material: Metal
5. Besides the standard key (key number 0H), six other keys are also available. See page 13.
6. For the contact block mounting position, see right.
7. For dimensions, see page 17.

Contact Block Mounting Position

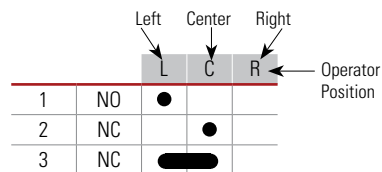

## Key Selector Switches (Sub-assembled)





### Contact Block

Style	Contacts	1NO	1NC
 	Finger-safe Screw terminal	CW-E10	CW-E01
	Dummy block	CW-DB	

### Contact Block Mounting Adaptor

Style	Part Number
	CW-CN

### Operator

Style	Position	Description	Black Bezel	Metallic Bezel	
 	2 position	Maintained	CW1K-2A	CW4K-2A	
		Maintained, key removed left only	CW1K-2B	CW4K-2B	
		Maintained, key removed right only	CW1K-2C	CW4K-2C	
		Spring return from right	CW1K-21B	CW4K-21B	
	3 position	Maintained	Maintained	CW1K-3A	CW1K-3A
			Maintained, key removed left and center only	CW1K-3B	CW4K-3B
			Maintained, key removed right and center only	CW1K-3C	CW4K-3C
			Maintained, key removed center only	CW1K-3D	CW4K-3D
		Maintained, key removed left and right only	CW1K-3E	CW4K-3E	
		Maintained, key removed left only	CW1K-3G	CW4K-3G	
		Maintained, key removed right only	CW1K-3H	CW4K-3H	
		Spring return from right, key removed left and center only	CW1K-31B	CW4K-31B	
		Spring return from right, key removed center only	CW1K-31D	CW4K-31D	
		Spring return from right, key removed left only	CW1K-31G	CW4K-31G	
		Spring return from left, key removed right and center only	CW1K-32C	CW4K-32C	
Spring return from left, key removed center only	CW1K-32D	CW4K-32D			
Spring return from left, key removed right only	CW1K-32H	CW4K-32H			
Spring return two-way, key removed center only	CW1K-33D	CW4K-33D			

2 keys supplied with operator.

# Dimensions (mm)

## Illuminated Pushbuttons

### Round Flush

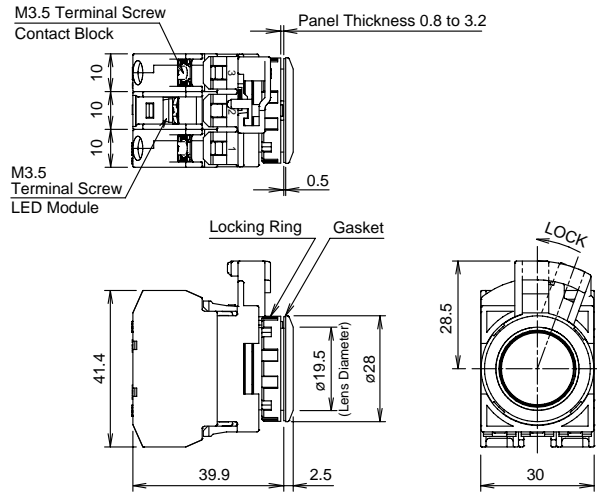

### Round Extended

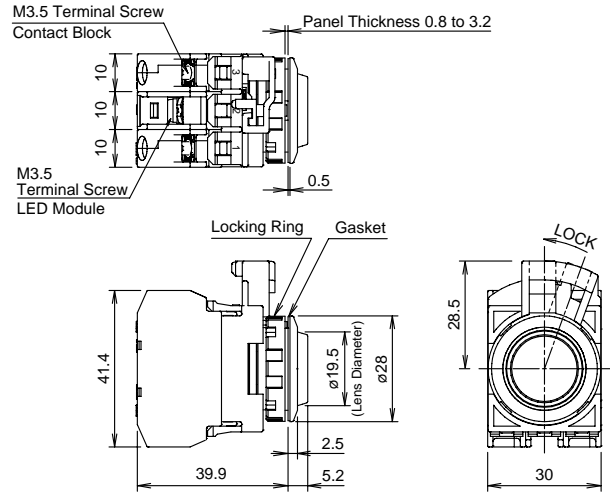

## Pushbuttons

### Round Flush

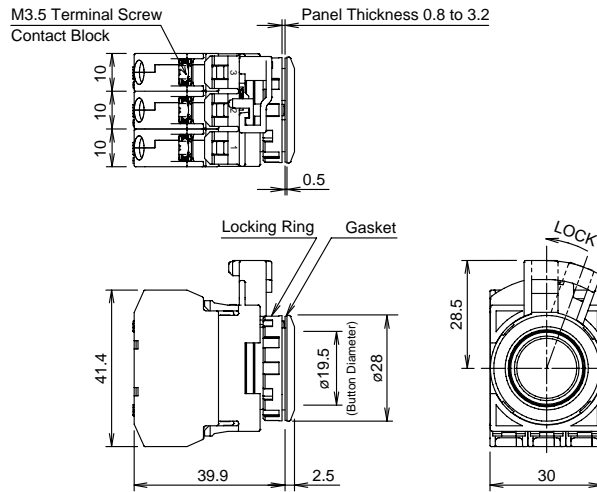

### Round Extended

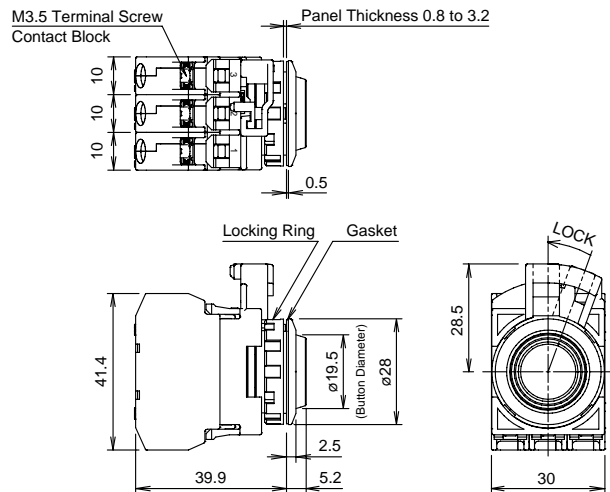

## Pilot Lights

### Round Flush

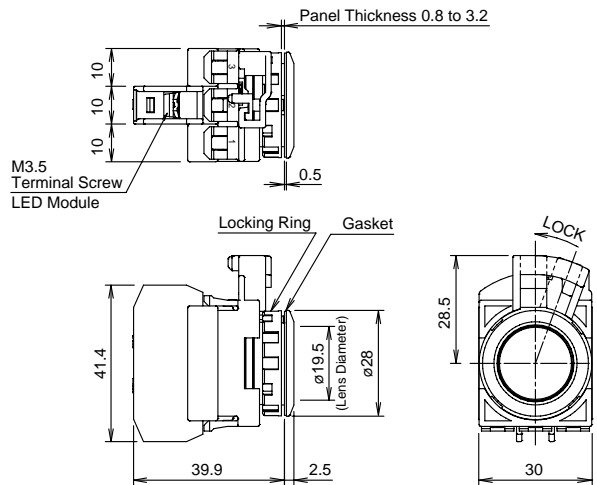

### Round Dome

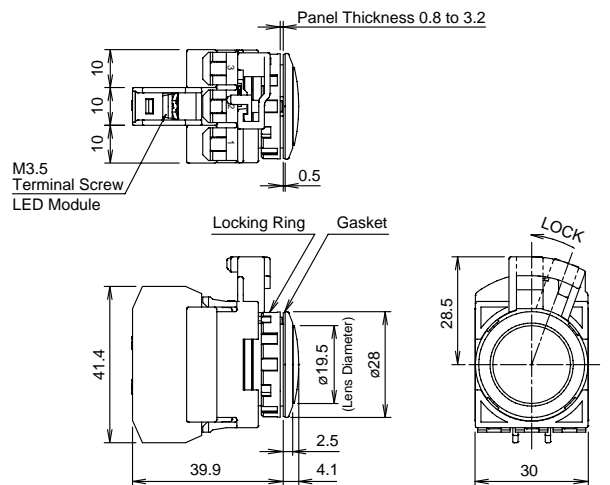



## Selector Switches

### Knob Operator

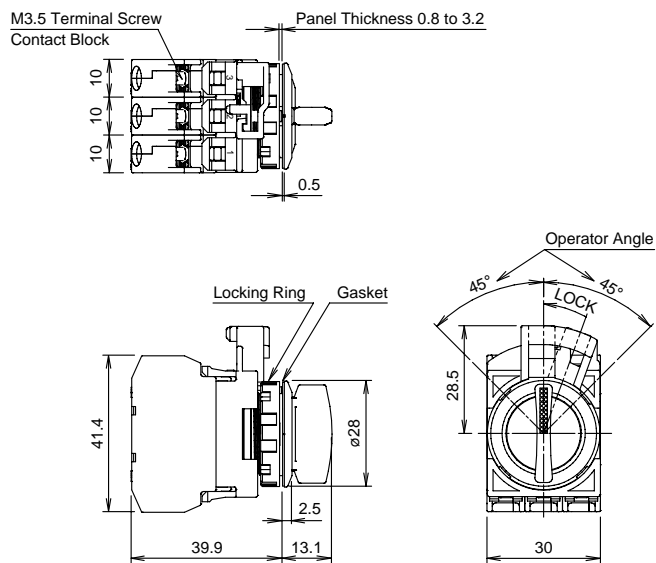

### Lever Operator

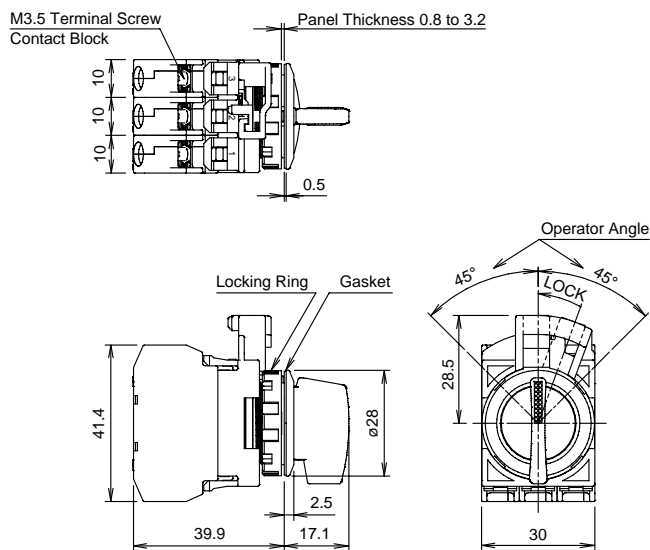

## Key Selector Switches

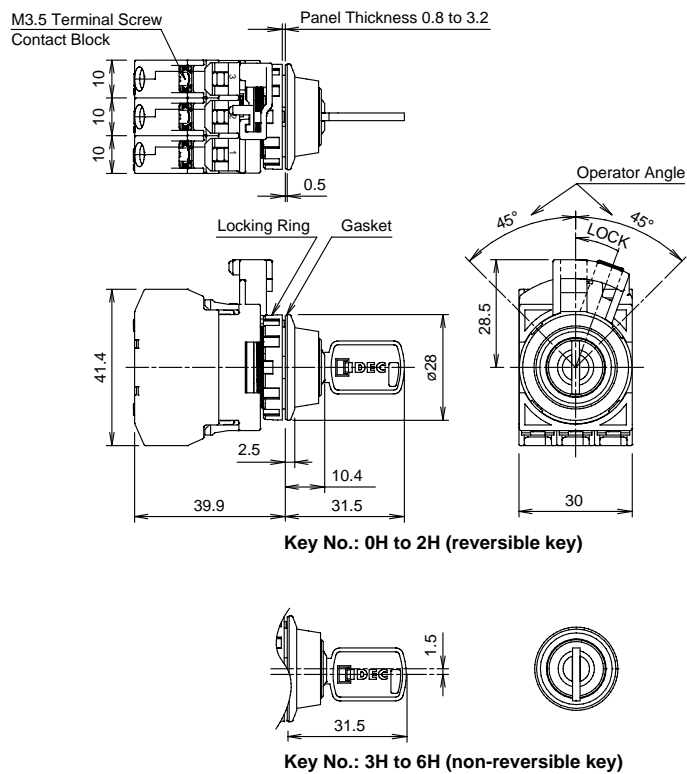

## Dimensions: Keys

### Reversible Key

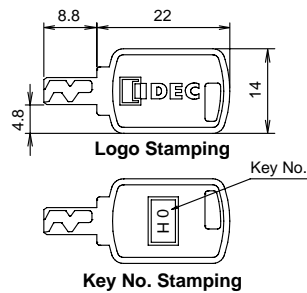

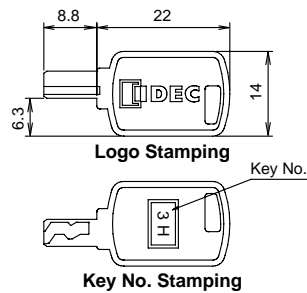

### Non-reversible Key



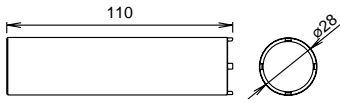

# Accessories/Parts

## Accessories

Shape	Material	Part Number	Package Quantity	Remarks
	Brass	MW9Z-T1	1	<ul style="list-style-type: none"> <li>Used to tighten the locking ring when installing the CW series control unit in a panel cut-out.</li> <li>Weight: Approx 150g</li> </ul> 
	Polyamide (black)	LW9Z-BP1	1	<ul style="list-style-type: none"> <li>Used to plug an unnecessary <math>\varnothing 22.3</math>mm hole in the panel.</li> <li>Degree of protection: IP65</li> <li>Panel thickness: 0.8 to 6.0 mm</li> </ul>

## Replacement Parts

Shape	Material	Part Number	Remarks
Lens 	1 Round Flush Polyalylate CW9Z-L11 <sup>Ⓢ</sup>		Color code <sup>Ⓢ</sup> : A (amber), C (clear), G (green), R (red), S (blue), Y (yellow) Use a clear (C) lens for white (PW) illumination. 1: For illuminated pushbutton, pilot light 2: For illuminated pushbutton 3: For pilot light
	2 Round Extended Polyalylate CW9Z-L12 <sup>Ⓢ</sup>		
	3 Round Dome Polyalylate CW9Z-L15 <sup>Ⓢ</sup>		
Contact Blocks 	1NO Polyamide (black) CW-E10		Housing color: Blue Terminal No.: 3-4
	1NC Polyamide (black) CW-E01		Housing color: Reddish purple Terminal No.: 1-2
Dummy Block 	Polyamide (black)	CW-DB	
Locking Ring 	Polyamide (black)	CW9Z-LN	
Gasket 	Nitrile rubber	CW9Z-WM	Waterproof gasket between CW control unit bezel and the mounting panel.
Spare Key 	Zinc (nickel-plated)	LA9Z-SK-□	Specify a key No. in place of □. 0H: Standard key (reversible) 1H to 2H: Reversible key 3H to 6H: Non-reversible key For dimensions, see page 16.

## LED Modules

Shape	Operating Voltage Range	Current Draw	Part Number	Illumination Color Code <sup>Ⓢ</sup>
	6V AC/DC $\pm 10\%$	15 mA	CW-EAQ2 <sup>Ⓢ</sup>	Specify an illumination color code in place of <sup>Ⓢ</sup> in the Part Number A: amber G: green PW: white R: red S: blue
	12V AC/DC $\pm 10\%$	15 mA	CW-EAQ3 <sup>Ⓢ</sup>	
	24V AC/DC $\pm 10\%$	16.5 mA	CW-EAQ4 <sup>Ⓢ</sup>	
	100/120V AC $\pm 10\%$	18 mA	CW-EAQH <sup>Ⓢ</sup>	
	230/240V AC $\pm 10\%$	18 mA	CW-EAQM4 <sup>Ⓢ</sup>	

Use a white (PW) LED module for yellow (Y) illumination.

## Safety Precautions

Turn off the power to CW series switches before installation, removal, wiring and maintenance. Failure to turn power off may cause electrical shocks or fire hazard.

When wiring, use wires of a proper size to meet the voltage and current requirements. Tighten the M3.5 terminal screws to a tightening torque of 1.0 to 1.3 N·m. Failure to tighten the terminal screws may cause overheating and fire.

## Operating Instructions

### Notes for Operation

When using the CW series switches in a safety-related circuit of a control system, observe safety rules and regulations of each country concerning particular applications of the actual machines and facilities. Perform risk assessment before operation to ensure safety.

### Operating Conditions

In corrosive gas or high-temperature, high-humidity environments, contact failure due to corrosion or color change or breakage of the housing may occur.

Main parts of the CW series switches are made of plastic. Do not scratch the surface with a sharp object or apply excessive electric shock or load, otherwise the switches may be damaged. In particular, keep the button, lens and bezel from such damage, otherwise appearance and function may be impaired.

Do not apply detergents, cutting oils, or chemicals which may impair the function and appearance of the CW series switches.

### Panel Mounting

First remove the contact block and then the locking ring from the operator. Insert the operator into the panel cut-out from the front, tighten the locking ring from the back, then install the contact block to the operator.

### Mounting Hole

1. Mounting hole dimensions are in compliance with IEC60947-5-1.
2. If the anti-rotation projection is removed from the bezel, CW series switches can be mounted in  $\varnothing 22.3\text{mm}$  mounting holes. To remove the anti-rotation projection, remove the gasket and use cutting pliers to break the projection.

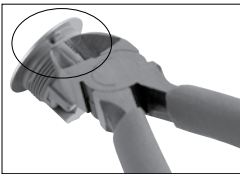

### Removing and Installing the Contact Unit

1. To remove the contact block from the operator, push the yellow locking lever and turn it to the left.

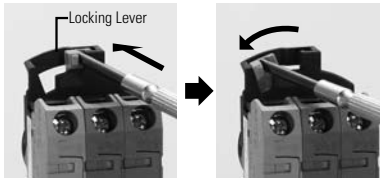

2. To install, align the TOP marking on the operator with the TOP marking on the contact block mounting adaptor, and turn the locking lever to the right.

### Installation in Panel Cut-out

Remove the locking ring from the operator. With the anti-rotation projection on the operator aligned with the recess in the mounting hole, insert the operator into the mounting hole. Tighten the locking ring from the rear of the panel.

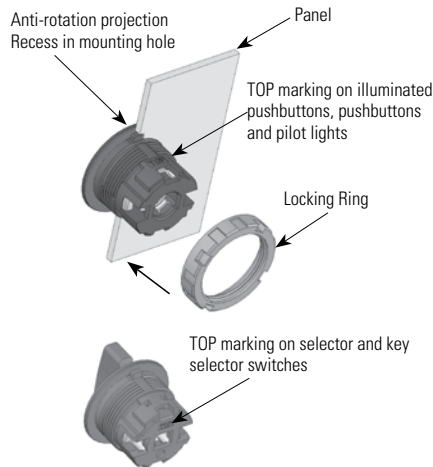

### Note for Panel Mounting

When installing the operator in a panel cut-out, use the optional locking ring wrench (MW9Z-T1) to tighten the locking ring to a recommended tightening torque of 1.2 N·m. Do not use pliers and do not tighten excessively, otherwise the operator may be damaged.

### Illuminated Pushbuttons and Pilot Lights

#### Removing the Lens

To remove the lens from an illuminated pushbutton or pilot light, insert a flat screwdriver under the flange of the lens at 90° from the TOP marking and twist the screwdriver.

Do not insert the screwdriver too far and do not apply excessive force to the lens, otherwise the bezel surface may be damaged.

#### Screwdriver Insertion Direction

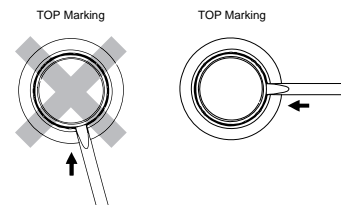

#### Screwdriver Insertion Angle

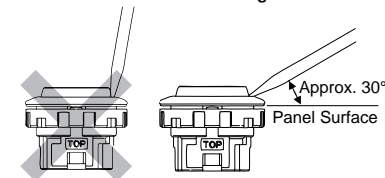

#### Installing the Lens

Turn the groove in the lens to the TOP marking on the operator housing. With the groove aligned with the ridge, press the lens in.

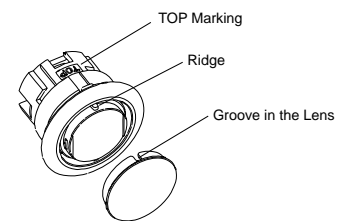

#### Marking

Marking film can be applied for inscriptions or identification. (Marking plates are not available for CW series illuminated pushbuttons and pilot lights.)

#### Applicable Marking Film Size

Illuminated Pushbutton (Round Flush) Pilot Light (Round Flush, Round Extended)	Illuminated Pushbutton (Round Extended)

Thickness: 0.2 mm maximum

Film material: Polyester (recommended)

Note: Film is not supplied and must be provided by the user.

## Operating Instructions con't

### Pushbuttons

Pushbutton caps cannot be removed. Do not tamper with the cap using a screwdriver or pliers, otherwise it may be damaged.

### Selector Switches

Turn the selector operator or key to the detent positions.

### Key Selector Switches

To prevent malfunction and damage, take the following precautions.

- Completely insert the key before turning.
- Do not remove the key while turning.
- Besides the standard key (0H), six other keys are available. Use only a key with a number that matches the number on the switches' key cylinder. (The standard key does not have a key number.)
- Keys are available in two shapes.
  - 0H (standard), 1H, 2H: reversible keys
  - 3H, 4H, 5H, 6H: non-reversible keys
 Make sure of correct insertion direction.

### Contact Blocks and LED Modules

To remove the contact block from the operator, insert a flat screwdriver under the latch and push the screwdriver down as shown below. Before removing the LED module, first remove all contact blocks, and then remove the LED module in the same manner.

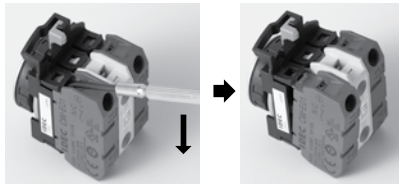

### Wiring

#### Applicable Wires

Stranded wire: 2.0 mm<sup>2</sup> maximum (14AWG)  
Solid wire: ø1.6 mm maximum

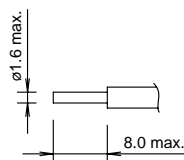

One or two wires can be connected to the terminal.

### Applicable Crimping Terminals

#### Spade terminal

When using crimping terminals, be sure to use insulating tubes or insulated crimping terminals.

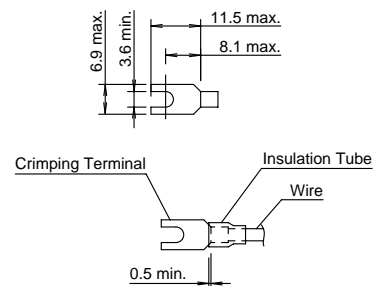

#### Ferrule

When connecting two ferrules to one terminal, use ferrules without insulation.

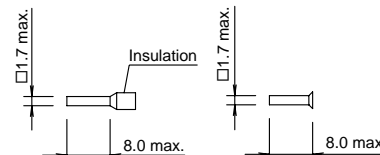

When using spade terminals or ferrules, ensure that they are inserted completely. Ring terminals cannot be used.

#### Screw Tightening Torque

Tighten the M3.5 terminal screws to a recommended torque of 1.0 to 1.3 N-m.

Die technischen Daten und sonstigen Beschreibungen dieser Druckschrift können ohne vorherige Ankündigung geändert werden.

## TREICHL - ATM Electronic

Auf der Bült 10 - 12  
D - 41189 Mönchengladbach

Telefon +49-2166/9585-45  
Telefax +49-2166/9585-47

E-Mail: atm@treichl.de  
Internet: www.atm-treichl.de